



SPP *Southwest
Power Pool*

**Facility Study
For
Generation Interconnection
Request
GEN-2014-001
(IFS-2014-001-8)**

*SPP Generator
Interconnection Studies*

*(#GEN-2014-001)
(#IFS-2014-001-8)*

March 2015

Revision History

Date	Author	Change Description
1/09/2015	SPP	Facility Study Draft Report Issued
3/05/2015	SPP	Final Facility Study Report Issued; Customer Comments Appended

Summary

Westar Energy (WERE) performed a detailed Facility Study at the request of Southwest Power Pool (SPP) for Generation Interconnection request GEN-2014-001/IFS-2014-001-8 (200.6 MW/Wind) located in Marion County, Kansas. The Interconnection Customer proposed in-service date for IFS-2014-001-8 is December 15, 2014. SPP has proposed the in-service date will be after the assigned Interconnection Facilities and Non-Shared Network upgrades are completed. Full Interconnection Service will require the Network Upgrades listed in the "Other Network Upgrades" section. The request for interconnection was placed with SPP in accordance with SPP's Open Access Transmission Tariff, which covers new generation interconnections on SPP's transmission system.

Phases of Interconnection Service

It is not expected that interconnection service will require phases however, interconnection service will not be available until all interconnection facilities and network upgrades can be placed in service.

Interconnection Customer Interconnection Facilities^{1,2}

The Interconnection Customer's generation facility consists of one hundred and eighteen (118) 1.7 G.E. wind turbines for a total generation capacity of 200.6MW. The 34.5kV collector system for this wind farm is planned to be connect to two (2) 345/34.5kV Interconnection Customer owned and maintained transformers at the Interconnection Customer owned substation. An approximate twelve (12) mile 345kV transmission circuit will connect the Interconnection Customer owned substation to the new WERE owned 345kV substation. The Interconnection Customer will be responsible for all of the transmission facilities connecting the Interconnection Customer owned substation to the Point of Interconnection (POI), at new 345kV bus at a new Westar Energy (WERE) owned 345kV substation, which will tap the WERE Wichita - Emporia Energy Center 345kV transmission line approximately forty-two (42) miles from Wichita.

The Interconnection Customer will be responsible for any equipment located at the Customer substation necessary to maintain a power factor of 0.95 lagging to 0.95 leading at the POI, including approximately 21.0 Mvar⁴ of reactors to compensate for injection of reactive power into the transmission system under light wind conditions. Also, the Interconnection Customer will need to coordinate with the Transmission Owner for relay, protection, control, and communication system configurations.

Transmission Owner Interconnection Facilities and Non-Shared Network Upgrades

To allow interconnection the Transmission Owner will need construct a new 345kV substation with a new three breaker ring bus and associated terminal equipment for acceptance of the Interconnection Customer's Interconnection Facilities. WERE has estimated a lead time for in-service date for the Interconnection Facilities and Non-shared

¹ Based on the information provided within the original DISIS and IFS Application.

² The Interconnection Customer has requested a modification study to change the wind generators to Gamesa generators. The evaluation of this modification is in progress and will not be included within this Interconnection Facilities Study.

⁴ Subject to change based on results of restudy discussed above.

Network Upgrades of ninety (90) weeks after an fully executed Generation Interconnection Agreement (GIA). At this time, GEN-2014-001/IFS-2014-001-8 is responsible for \$19,343,307 of Transmission Owner Interconnection Facilities and Non-Shared Network Upgrades. Table 1 displays the estimated costs for Transmission Owner Interconnection Facilities and Non-Shared Network Upgrades.

Table 1: IFS-2014-001-8 TOIF and Non-Shared Network Upgrades

Transmission Owner Interconnection Facilities and Non-Shared Network Upgrades Description	Allocated Cost (\$)	Allocated Percent (%)	Total Cost (\$)
Interconnection Substation - Transmission Owner Interconnection Facilities 345kV Substation work	\$600,000	100%	\$600,000
Interconnection Substation - Network Upgrades 345kV Substation work	\$18,743,307	100%	\$18,743,307
Total	\$19,343,307	100%	\$19,343,307

Shared Network Upgrades

The Interconnection Customer was studied within the DISIS-2014-001 Impact Study with Energy Resource Interconnection Service (ERIS) only. At this time, the Interconnection Customer is allocated \$0 for Shared Network Upgrades. If higher queued interconnection customers withdraw from the queue, suspend or terminate their GIA, restudies will have to be conducted to determine the Interconnection Customers' allocation of Shared Network Upgrades. All studies have been conducted on the basis of higher queued interconnection requests and the upgrades associated with those higher queued interconnection requests being placed in service. At this time, the Interconnection Customer is allocated the following cost for Shared Network Upgrade:

Table 2: GEN-2014-001/IFS-2014-001-8 Shared Network Upgrades

Shared Network Upgrades Description	Allocated Cost (\$)	Allocated Percent (%)	Total Cost (\$)
Currently GEN-2014-001 is not allocated Shared Network Upgrades	\$0	n/a	\$0
Total	\$0	n/a	\$0

Other Network Upgrades

Certain Other Network Upgrades are currently not the cost responsibility of the Customer but will be required for full Interconnection Service. At this time, no Other Network Upgrades are assigned to GEN-2014-001/IFS-2014-001-8.

Depending upon the status of higher or equally queued customers, the Interconnection Customer's in-service date is at risk of being delayed or their Interconnection Service is at risk of being reduced until the in-service date of these Other Network Upgrades.

Conclusion

Interconnection Service for GEN-2014-001/IFS-2014-001-8 will be delayed until the Transmission Owner Interconnection Facilities and Non-Shared Network Upgrades are

constructed. The Interconnection Customer is responsible for \$19,343,307 of Transmission Owner Interconnection Facilities and Non-Shared Network Upgrades. At this time, the Interconnection Customer is allocated \$0 for Shared Network Upgrades. After all Interconnection Facilities and Network Upgrades have been placed into service, Interconnection Service for 200.6 MW, as requested by GEN-2014-001/IFS-2014-001-8, can be allowed.

At this time the total allocation of costs assigned to GEN-2014-001/IFS-2014-001-8 for Interconnection Service are estimated at \$19,343,307.



**Generation Interconnection Facility
Study**

For

**Generation Interconnection Request
SPP-GEN-2014-001
SPP-IFS-2014-001-8**

December 18, 2014

Introduction

This report summarizes the results of a Generation Interconnection Facility Study performed for the Southwest Power Pool (SPP) by Westar Energy to evaluate a generation interconnection request by [Interconnection Customer] for 200 MW of wind-powered generation to the Westar Energy transmission system. The proposed interconnection is on the Wichita – Emporia Energy Center 345 kV line near Doyle, Kansas. A System Impact Study has been completed and the requested in-service date of the generating facility is December 15, 2015.

Project Location and Existing Facilities

The project is located in Marion County in central Kansas. The interconnection will be at a new 345 kV ring-bus substation on the Wichita – Emporia Energy Center 345 kV line near Doyle, Kansas. The substation will connect to customer facilities at 345 kV. Figure 1 shows the Regional Transmission Facilities.

Interconnection Facilities

Interconnection to the Westar Energy transmission system will be by way of a new 345 kV three position ring-bus switching station on the existing Wichita – Emporia Energy Center 345 kV transmission line. The new substation terminal will look towards Customer's facilities. Construction of this new substation terminal requires additional land adjacent to the existing transmission line right-of-way.

345 kV Substation Work

- **Ring Bus Substation (no metering or customer equipment included)**
The estimated cost includes three (3) 345 kV breakers, six (6) 345 kV switches, two (2) 345 kV motor operated switches, six (6) 345 kV CCVTs, four (4) 345 kV wave traps, new redundant primary relaying, relaying setting changes and trap tuning at Wichita and Emporia Energy Center, two (2) 345 kV full tension deadend structures, and all associated site, yard, cable, grounding and conduit work.
- **345 kV Substation (Equipment on customer side of meter)**
The estimated cost includes three (3) 345 kV arresters, one (1) 3000A motor operated switch, three (3) 345 kV arrester stands, one (1) 345 kV full tension dead-end structure, and one (1) 3-phase bus support. The estimate also includes all other associated yard, cable, grounding, communication, and conduit work.
- **345 kV Interconnection Revenue Metering**
The estimated cost includes three (3) 345 kV VTs, three (3) 345 kV CTs, and revenue interconnection metering plus all associated yard and conduit work.

\$12,703,990

345 kV Transmission Line Work

The estimated cost is for two three-pole steel dead end and turning structures to connect the existing Wichita – Emporia Energy Center 345 kV transmission line into the interconnection substation plus associated foundations and labor.

\$ 1,799,897

The total cost estimate for Transmission Owner Interconnection Facilities (Interconnection Metering) and Stand Alone Network Upgrades (345 kV Ring-bus Substation and Transmission Line Work) is:

\$12,703,990 345 kV Substation Work
\$ 1,799,897 345 kV Transmission Line Work
\$ 1,379,072 AFUDC
\$ 3,460,348 Contingency
\$19,343,307

This estimate is accurate to +/- twenty (20) percent, based on current prices, in accordance with Attachment A of Appendix 4 of the Interconnection Facilities Study Agreement. However, recent cost fluctuations in materials are very significant and the accuracy of this estimate at the time of actual settings cannot be assured.

20 weeks Engineering Time
40 weeks Procurement Time
30 weeks Construction Time
90 weeks Total

Westar Energy also maintains its own Facility Connection Requirements, which may be found at (<http://www.oasis.oati.com/WR/index.html>).

Figure 1 – Westar Regional Transmission System

The proposed interconnection is 42 miles from Wichita 345 kV substation

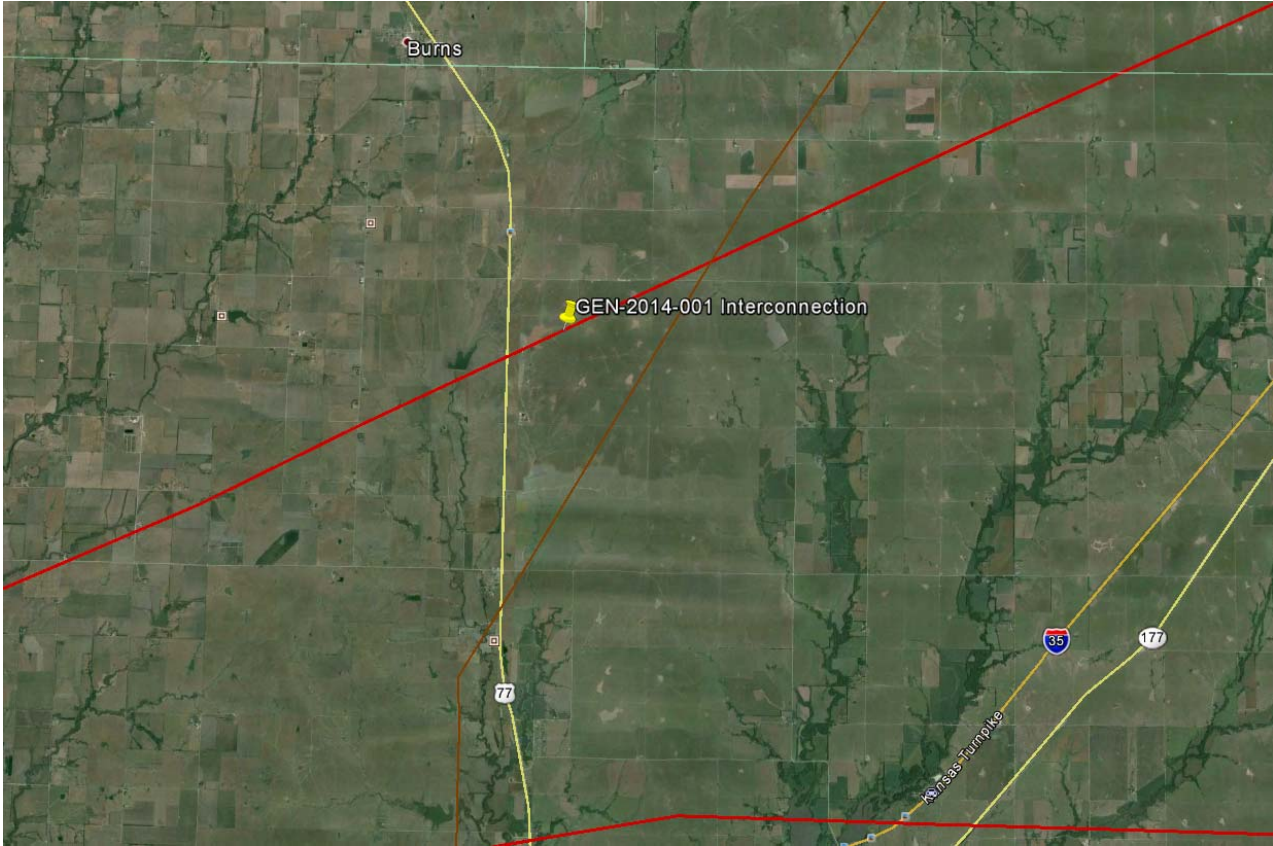
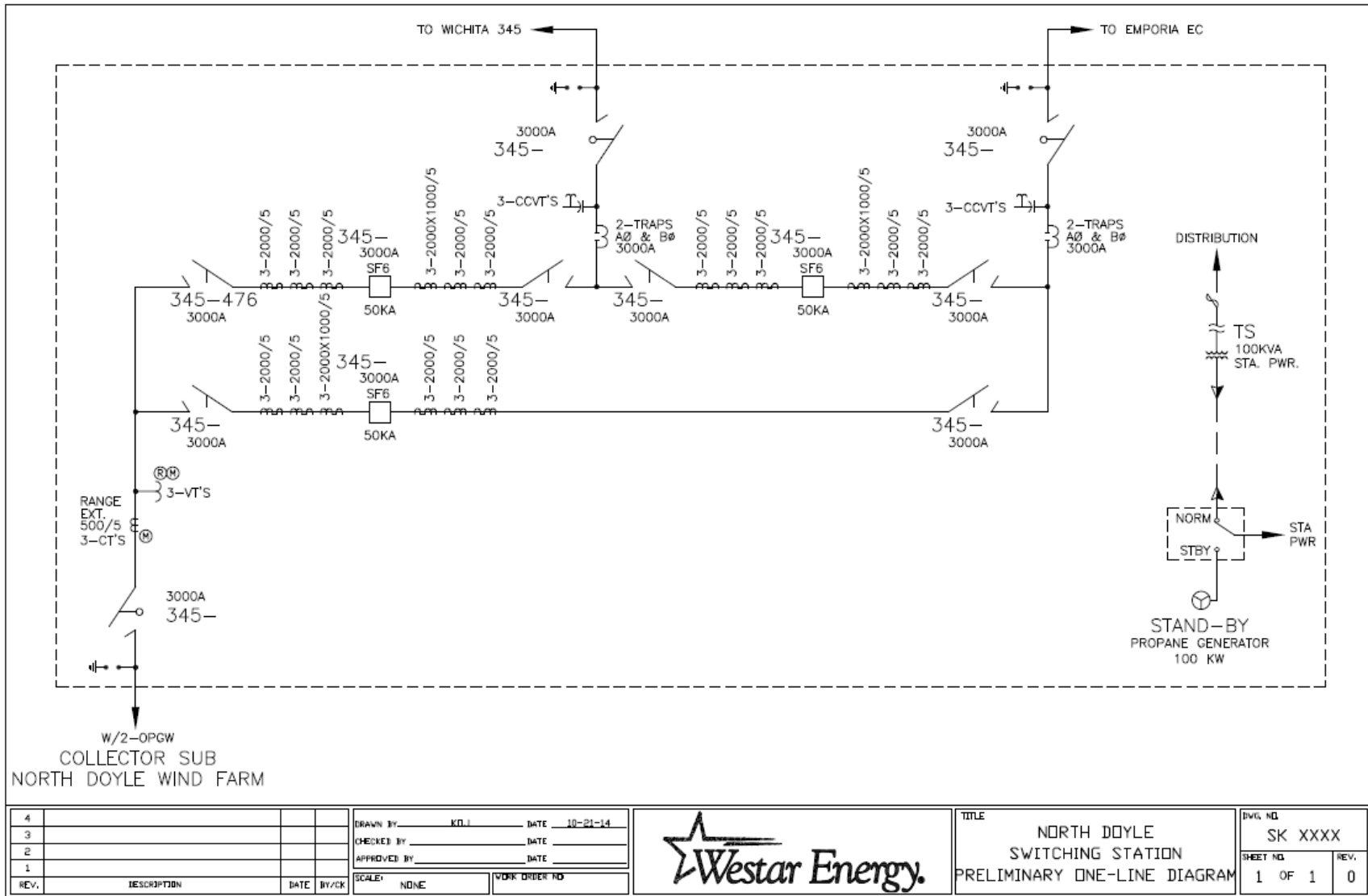

Figure 2 – Interconnection Substation Preliminary One-Line



4				DRAWN BY: KDJ	DATE: 10-21-14
3				CHECKED BY:	DATE:
2				APPROVED BY:	DATE:
1				SCALE: NONE	WORK ORDER NO:
REV.	DESCRIPTION	DATE	BY/CHK		



TITLE
 NORTH DOYLE SWITCHING STATION
 PRELIMINARY ONE-LINE DIAGRAM

DWG. NO.	SK XXXX
SHEET NO.	1 OF 1
REV.	0

GROUP: ESUB USER: PRELIM CAD FILE NO: SK XXXX

Figure 3 – Interconnection Substation Preliminary Layout

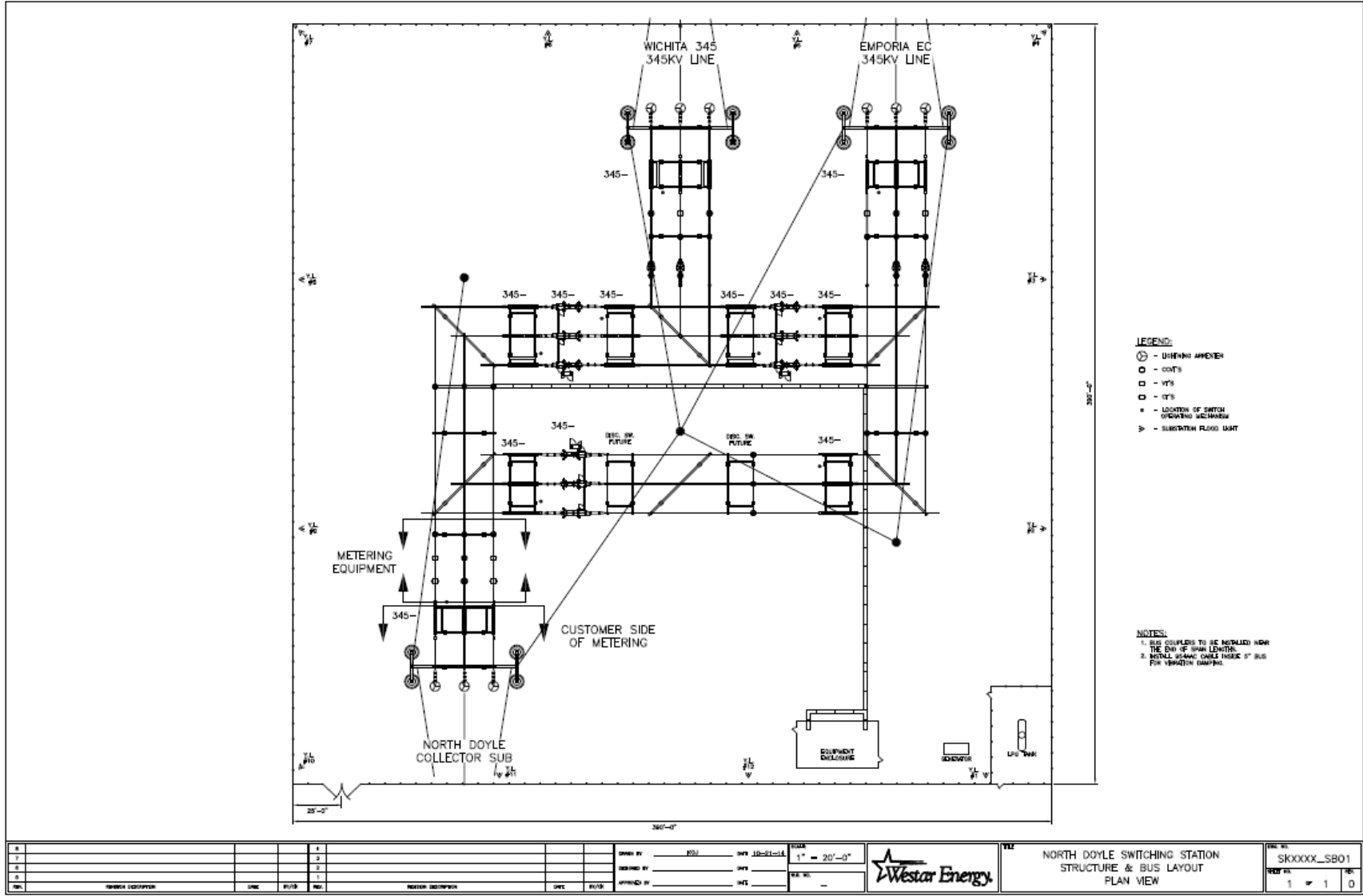

Results of Short Circuit Analysis

As a part of this Facility Study, a short circuit study was performed to determine the available fault current at the interconnection bus using PSS/E's activity SCMU. The interconnection bus was modeled as a tap on the Wichita-Emporia Energy Center 345 kV line approximately 42 miles out of Wichita 345 kV substation. The 2015 and 2025 Summer Peak 2014 Series MDWG Final Reduced cases were used in the study. No GEN-2014-001 Wind Farm generation was in service for this analysis. As a result, the numbers generated represent the available utility interconnection fault current:

2015 Summer:

- For a 3-Phase fault at the GEN-2014-001 interconnection, the fault current is estimated to be 9819 Amps.
- For a Phase-to-Ground fault at the GEN-2014-001 interconnection, the fault current is estimated to be 6141 Amps.

2025 Summer:

- For a 3-Phase fault at the GEN-2014-001 interconnection, the fault current is estimated to be 9929 Amps.
- For a Phase-to-Ground fault at the GEN-2014-001 interconnection, the fault current is estimated to be 6180 Amps.

– 345kV Utility Interconnection Station

**RE: Response Comments to: Facility Study for Generation Interconnection Request
GEN-2014-001 (IFS-2014-001-8)
SPP Generator Interconnection Studies (#GEN-2014-001) (#IFS-2014-001-8) January 2015**

Page 3:

Summary

Change 200.6 MW to 199.5 MW name plate
COD change to October 1, 2016

Interconnection Customer Interconnection Facilities

Change from GE 1, 7 MW units to Gamesa G 114-2.1MW units (95 units total for an output of 199.5 MW)
Transmission Gen-tie distance is 18 miles and not 12 miles from POI

Transmission Owner Interconnection Facilities and Non-Shared Network Upgrades

90 weeks – this is very long time frame and we would like to request “Option to build” and “P&E Agreement to control time frame and procurement of long lead items

Reactive power compensation; the report mentions 21 MVA, we have contemplated using 13 MVA.

Page 4:

Good Faith Estimate of \$ 19,343,307- We disagree with this estimate as it is significantly over priced based on our direct experience and also provided costs estimate from our BOP/EPC partner. In addition, in our understanding of FERC jurisdictional interconnection the SIS or DISIS study shall provide “good faith estimate” to 20% accuracy. This study costs was \$ 10,000,000. The Facilities study shall also comply with 20% accuracy and shall not deviate by 100% of SIS costs estimate using the same work scope for interconnection. We request this costs being revised accordingly.

Page 5 and 6:

Conclusion;

We disagree with provided cost estimate, Change name plate to 199.5 MW.

Westar Generation Interconnection Facility Study

Page 1 Comments;

Change COD to October 1, 2016

Project location, and Existing Facilities;

Figure 1, they are showing the old POI. The new location is at the crossing of Highway 77 and 345 KV line (contemplated on the West side of the Highway)

345 kV substation work;

- Ring Bus Substation (no metering or customer equipment included)
 - 3 – 345 kV Breakers – One Line shows 3,000 AMP- Is 2,000 AMP breakers sufficient?
 - 7 – 345 kV Switches -Only (2) below are broken out as motor operated switches?

- 4 – 345 kV Wave Traps (PLCC) – We have contemplated the use of OPGW Fiber. We are assuming the PLCC is preferred over POGW?
 - Is there additional equipment required in control building for this as well?
 - 345 kV Substation (Equipment on customer side of meter)
 - 1 3000 Amp Motor Operated Switch
 - 2,000 Amp Switches. Ten (10) totals are referenced in the document but only (9) are shown.
 - 1 – 3 Phase Bus Support – Our layout did not require this...Not reflected in drawing?- see attached POI sketch
 - 345 kV Interconnection Revenue Metering
 - 3 – 345 kV VT's
 - 3 – 345 kV CT's
 - Schedule
 - Prolong schedule duration, we would like to request "Option to build"
- **Drawings / One Line**
 - Lighting
 - Plan is showing 11 self-supporting light structures around the Site. We had anticipated on using the Dead End Structures and Static Masts to hang double lighting. They show the stand alone structures which would add significant dollars.
 - Yard Size
 - Westar yard size is 390 x 390. [REDACTED] yard size is 280' x 300'. We add significant dollars for rough and fine grading, finish rock, fencing, and grounding provision. Would they only have one double gate entrance, what around site civil requirements (finish rock, inside road, etc.)?
 - Lightning Protection Scheme
 - The Scheme used by Westar includes 3 Static Masts and much more protection across equipment. We did not cross any equipment and has a ring around the outside of the equipment. This would add significant dollars.
 - Line In & Out
 - The existing lines connecting to the interconnect are showing coming in at the same location. The way the line runs is from Northeast. It would make much more sense to have the line come in similar to [REDACTED]'s layout, eliminating most of the work outside the interconnection.
 - Layout of Yard
 - The [REDACTED] Collector T-Line will be coming in from the North Side of the project.
 - Control building Sizing
 - Westar is showing a 25' x 40' (I used on-screen takeoff to size) vs. HVT 15' x 25' building. [REDACTED] got sizing from CEG's westar interconnection they did previously.
 - Trenwa
 - Westar showing 410 LF of trewa, We used 110 LF and conduits to run to middle of interconnection.
 - Future Work
 - General Arrangement is showing future switches in interconnection. Would those be required at this time? This would add additional \$ and contribute to yard size increase.
 - Bus Size Requirements
 - We used 4" bus, does Westar have additional requirements for this?
 - Bus Supports
 - Westar Design looks to have more bus supports than we proposed.
 - Station Service

- One Line Showing Station Service, We used a generator and assumed power would be brought to interconnection by others, installed and hooked up by [REDACTED].
- Control Building Location
 - We had centered the control building which has less control cabling.

